

KEMS-112 ELECTROMECHANICAL ICE CORE DRILL

B. B. KUDRYASHOV, N. I. VASILIEV and P. G. TALALAY

*Antarctic Research Office, St. Petersburg Mining Institute,
199026 St. Petersburg, 21 line, 2, Russia*

Abstract: Design of the KEMS-112 electromechanical ice core drill (Russian abbreviation of core electromechanical drill, number 112 means final hole diameter) and results of drilling, bore-hole and core study, carried out on Vavilov Glacier, Severnaya Zemlya, and at Vostok Station, East Antarctica, are described.

Characteristics data and description of the KEMS-112 drill suspended on cable and the surface technical devices are given.

In 1984, 1986 and 1988, the KEMS-112 drill was used for core drilling on Vavilov Glacier up to the depths of 89, 152 and 461 m. The last bore-hole reached the bed of the glacier and pierced subglacial frozen rocks to the depth of 2.3 m. In 1989 at Vostok Station a deep bore-hole, drilled by a thermal drill, was deepened by the KEMS-112 drill from the depth of 2428 m up to 2546 m.

1. Introduction

Core drilling is considered to be the most effective method for study of past and present glacier development. More than 150 years ago, in 1841, one of the creators of glacial theory, L. AGASSIZ, had the first experience of ice drilling on Lower Aar Glacier, Alps, where the bore-hole was bottomed at the depth of 46 m.

Thermal drills suspended on cable are very simple in construction and enable deep bore-holes to be drilled in firm and ice (KUDRYASHOV *et al.*, 1991a). However, mechanical drilling consumes less energy and penetrates (UEDA and GARFIELD, 1969; GUNDESTRUP *et al.*, 1984). Boring of subglacial rocks and ice containing mineral inclusions becomes possible only by using exploratory drilling equipment or electromechanical drills suspended on cable.

2. Drilling Equipment

Developed in St.-Petersburg Mining Institute, Russia, the KEMS-112 electromechanical ice core drill (BOBIN *et al.*, 1988) is designed for core drilling in glaciers and subglacial rocks to a depth of 4000 m. The drill (Fig. 1) consists of a core chamber, driving electric motor with gear reducer, pump, antitorque system, hammer block, electric chamber, and cable termination. The total drill length, depending on the length of the core barrel, is 7–12 m, the drill weight is 120–180 kg.

The core chamber consists of a drill head (1) with three bits and three core catchers, core barrel (2), nipple (3), barrel (4), and chips filter (5). The outer/inner drill head diameters in different modifications are 112–116/85–89 or 132–135/107 mm. The corresponding outer/inner core barrel diameters are 108/99 or 127/117 mm, core barrel length is 1.5–3.0 m.

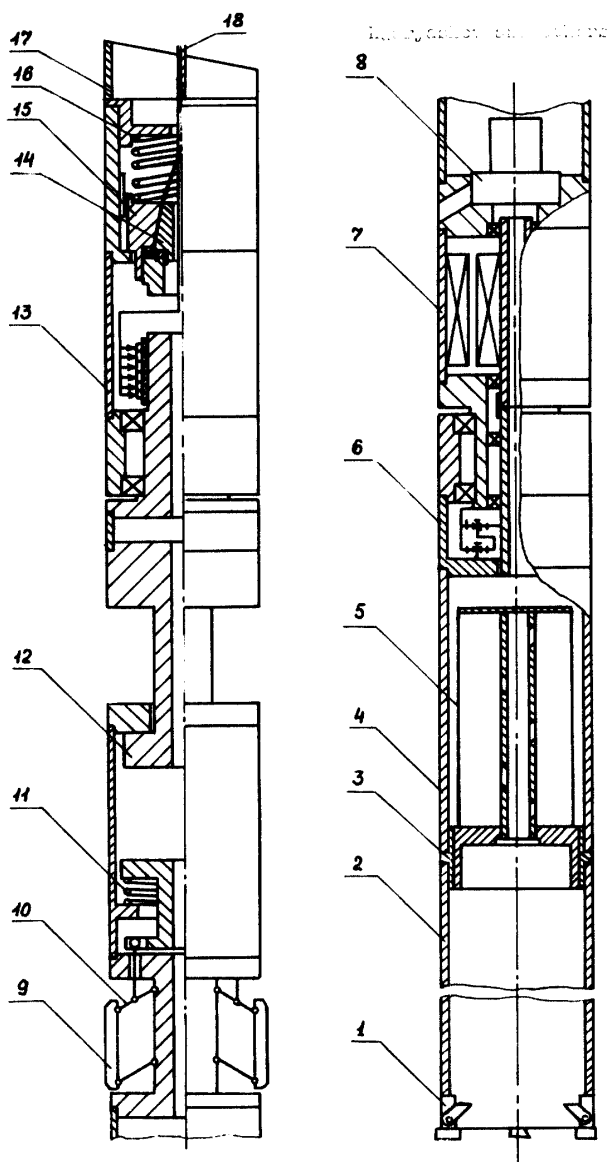

Fig. 1. Scheme of the KEMS-112 electromechanical ice core drill: 1-drill head, 2-core barrel, 3-nipple, 4-barrel, 5-chips filter, 6-gear reducer, 7-driving electric motor, 8-pump, 9-skates, 10-levers system, 11-spring, 12-hammer block, 13-electric chamber, 14-copper cone, 15-plug, 16-spring, 17-chips collector, 18-cable.

The power of the driving electric type three-phase AC motor (7) with nominal voltage 220 V and rotation speed 2800 rpm is 2.2 kW. The two-step gear reducer (6) lowers the core chamber rotation speed to 230 rpm.

The voltage of the electric type DC motor of the rotary type pump (8) can be changed from 15 to 27 V with maximum current of 12 A. The independent smoothly regulated electric drive of the pump provides continuous circulation of the hole liquid during drilling and also other technological operations (bore-hole cleaning, for example).

The antitorque system intending to balance the torsion torque consists of a lever system (10), spring (11) and three skates (9). The force of each skate on the bore-hole

walls, depending on the antitorque system outer diameter, varies from 540 to 980 N.

The hammer block (12) is to break the core if necessary to extract a stuck drill. The weight of the hammer block, with the traveling upper part of the drill, is about 40 kg. The free run of the hammer block is 300 mm.

The electric chamber (13) acts as a rotary current collector and is intended to prevent cable twisting in case of failure of the antitorque system.

In termination the cable armor is clutched between the traveling plug (15) and copper cone (14). The drill weight is taken up during penetration by the spring (16). The chips collector (17) is fastened on top the drill for bore-hole cleaning during hoisting.

The diameter of the type KG7-95-180 cable (18) is 16.5 mm, breaking strength is 95 kN, and weight in air is 865 kg/km. The cable has six teflon-insulated conductors with area of cross-section 2.5 mm² each and central coaxial conductor of the same cross-section.

At the glaciological base of the Arctic and Antarctic Research Institute, situated on the

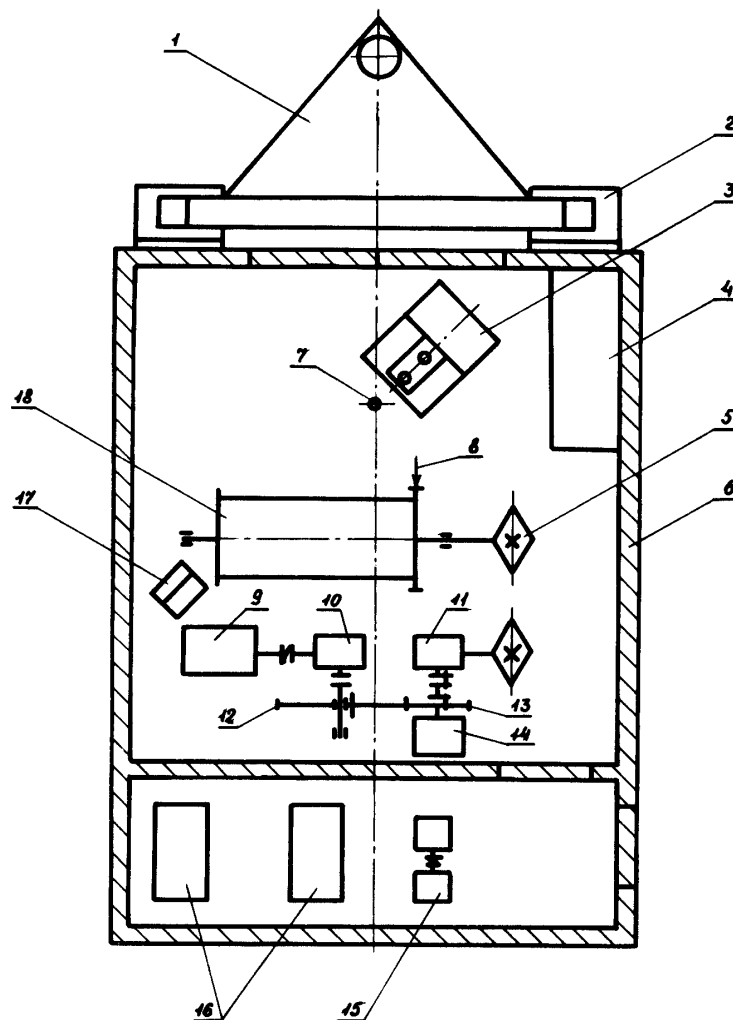

Fig. 2. Plan of drilling shelter at glaciological base on Vavilov Glacier: 1-hitching device, 2-sledge, 3-assembling/disassembling device, 4-joiner's bench, 5-chain-drive, 6-house, 7-bore-hole mouth, 8-hand brake, 9-electric motor, 10-worm reducer, 11-gear box, 12, 13-gear clutch, 14-electric motor, 15-motor-generator system, 16-diesels, 17-control desk, 18-winch.

northern part of Vavilov Glacier, Octyabrskoy Revolutsii island, Severnaya Zemlya archipelago, the drilling shelter (Fig. 2) was built. Its hut (6) measures $4.2 \times 9.0 \times 2.5$ m. Above the mouth of the bore-hole (7) a pyramidal tower with height 9.0 m was mounted.

The lowering/hoisting operations are carried out by the winch (18) with an electric DC motor (14) (power 7 kW) through gear-box (11) and chain drive (5). When the drill is near the bottom of the bore-hole or on the surface, the motor (14) is switched off, winch (18) is stopped by hand brake (8) and gear clutch (12, 13) engages the unit for regular drill transference. By switching on electric motor (9) (power 1 kW) winch (18) begins to turn through worm reducer (10).

The electric DC power is provided from two diesel electric generators (16) type 2E/16AU with operational power 16 kW through motor-generator system (15) to electric motors (9) and (14). A unified control desk (Fig. 3) has several independent electrical systems in order to control the characteristics of thermal and electromechanical drills, and surface equipment.

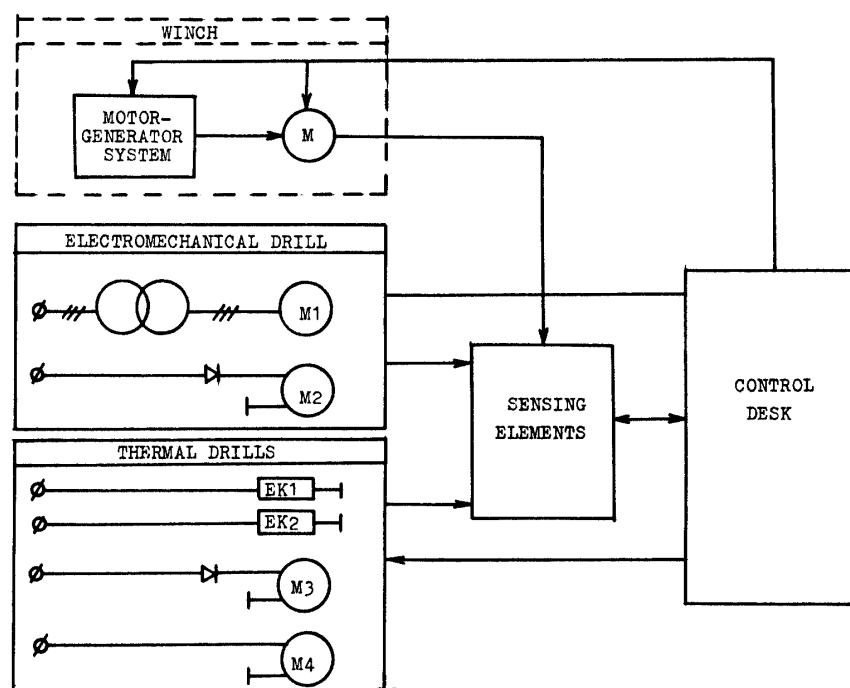

Fig. 3. Block diagram of electric tools: M-electric motor of winch, M1-driving electric motor of electromechanical drill, M2-electric motor of pump, M3-electric motor of pump, M4-electric motor of air compressor, EK1-thermal drill head, EK2-heating of thermal drill.

Near the mouth of the bore-hole the assembling/disassembling device (Fig. 4) is situated. For core and chips recovery, the device is driven to the mouth, and the drill (7) is clutched in yokes (2, 4, 5). Then the traveling yoke (2) is turned by the core barrel (3). Three springs (14) take up part of the core barrel weight. After unscrewing the core barrel, the yokes (5) are opened, drill (7) is hoisted, and post (8) with core barrel is turned to the horizontal position. The core is recovered from the core barrel, and the chips collector from the upper part of the drill.

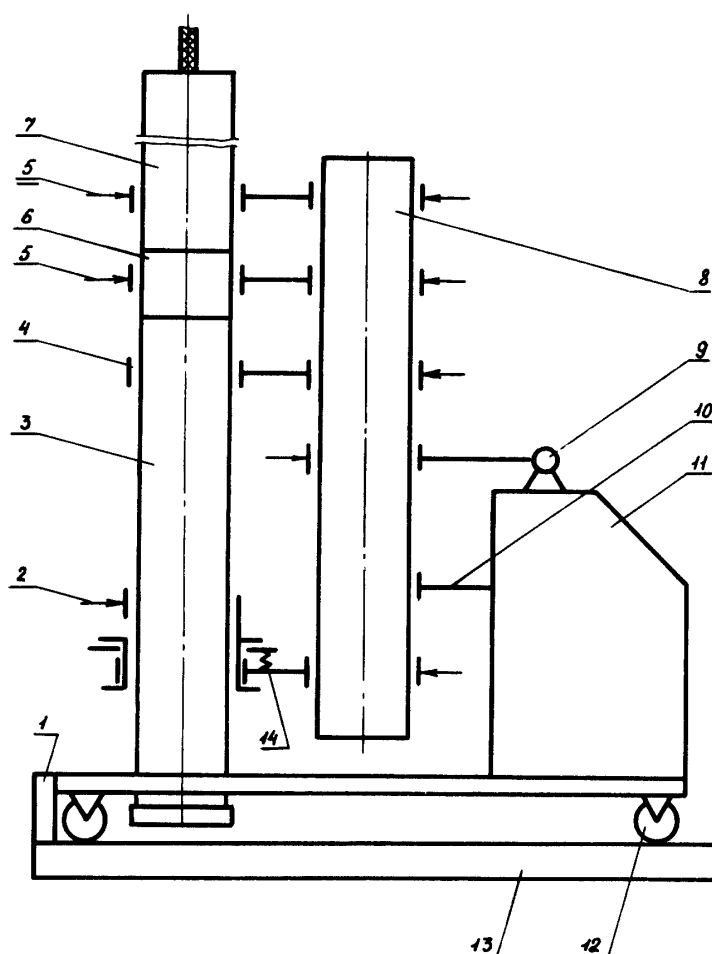

Fig. 4. Scheme of assembling/disassembling device: 1-lug, 2-traveling yoke, 3-core barrel, 4-free centralizer yoke, 5-yokes, 6-nipple, 7-upper part of the drill, 8-post, 9-hinge, 10-lug, 11-frame, 12-rollers, 13-rails, 14-springs.

During deep ice drilling the bore-hole must be filled with a liquid in order to create hydrostatic pressure on the walls and bottom of the bore-hole and prevent hole closure. On Vavilov Glacier the liquid was the pure kerosene type TS-1, while at Vostok Station (East Antarctica) the bore-holes were filled by a mixture of TS-1 and freon-11 (PASHKEVICH and CHISTYAKOV, 1989). The density and viscosity of this mixture change with temperature (Fig. 5). Now we are looking for another densifier, because in accordance with the Montreal Protocol the use of freon-11 is only allowed up to 1995.

3. Drilling Operations on Vavilov Glacier

The tests of the KEMS-112 electromechanical drill were carried out in three stages. In the first stage the tests from unit to unit, and first of all of the gear reducer and chips collector, were carried out. The second test stage included investigation of the influence of the drill head construction and the cutting efficiency of ice and frozen rocks (VASILIEV *et al.*, 1988). In the third stages in 1984, 1986 and 1988, experimental investigations *in situ*

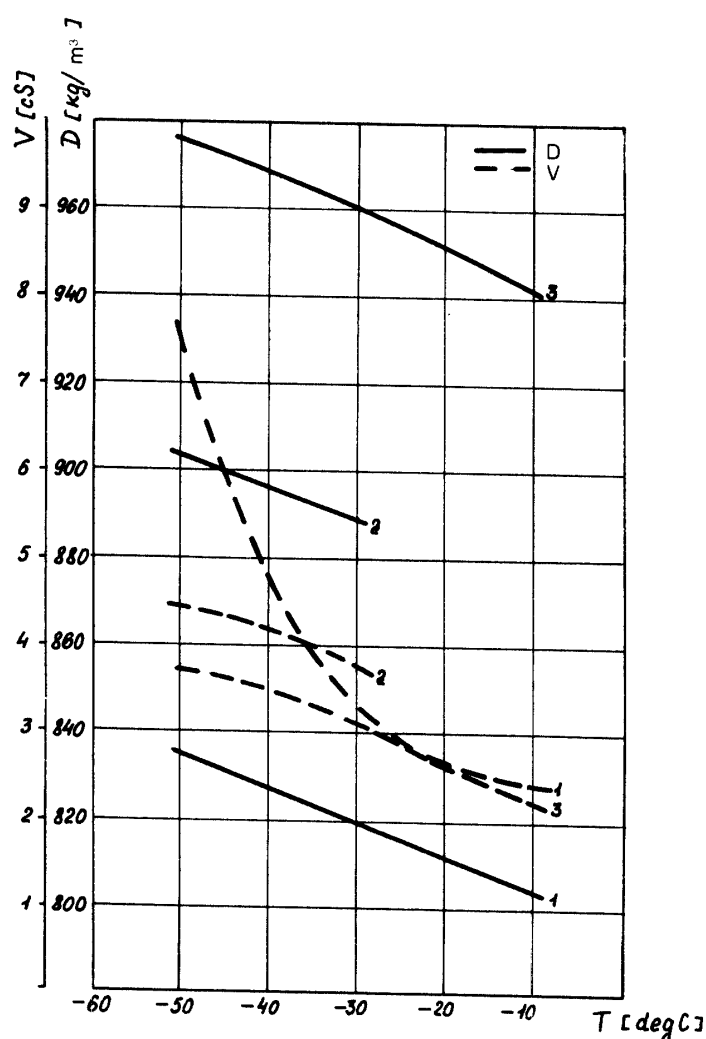

Fig. 5. Hole liquid density D and viscosity V versus temperature T : 1-kerosene TS-1, 2-mixture of kerosene TS-1 and 5% vol. freon-11, 3-mixture of kerosene TS-1 and 20% vol. freon-11.

were carried out on Vavilov Glacier, where the bore-holes were bottomed at 89, 152 and 461 m (KUDRYASHOV *et al.*, 1991b).

In all cases the upper permeable interval was drilled without hole liquid filling by a TELGA-14M type thermal drill. Then the bore-hole was filled by kerosene TS-1 to a height equal to the length of the electromechanical drill, and core drilling was continued by the KEMS-112 (Tables 1, 2 and 3).

The pump productivity and the drilling pressure were controlled by sensing resistor elements mounted in the drill. The signals were registered by a type N-327/5 self-recording voltmeter. The energy output of the driving electric motor was registered by a self-recording type N-396 watt meter. The voltage and current of the drill and pump electric motors were checked by control and measurement apparatus on the control desk.

During drilling in ice, the drilling pressure was about 100–200 N, and pump output was 25–30 l/min. The power consumed by the driving electric motor in the cutting and rotation of the core chamber was 100–200 W, depending on the penetration rate. The total

Table 1. The technological characteristics of ice core drilling by the KEMS-112 electromechanical drill on Vavilov Glacier (15.05.84–24.05.84).

Characteristics		Intervals, m	
		30.0–43.6	43.6–89.0
Diameter of drill head	mm		
	outer	116	112
	inner	87	87
Length	m		
	barrel	1.5	1.5
	filter	1.8	1.8
Chips density in filter	kg/m ³	300-380	300-390
Average length of run	m	0.62	0.63
Average rate of penetration	m/h	19.6	23.6
Average core production rate	m/day	3.4	6.5

Table 2. The technological characteristics of ice core drilling by the KEMS-112 electromechanical drill on Vavilov Glacier (13.05.86–21.05.86).

Characteristics		Intervals, m	
		36.9–52.4	52.4–151.8
Diameter of drill head	mm		
	outer	116	112
	inner	92 ; 93	87
Length	m		
	barrel	1.5	1.5
	filter	1.9	1.9
Chips density in filter	kg/m ³	360-400	345-430
Average length of run	m	0.73	1.01
Average rate of penetration	m/h	16.9	28.4
Average core production rate	m/day	5.1	16.5

energy consumption of the drill was about 1.5 kW, taking into account the loss in the 700 m-long cable.

In order to study the cutting efficiency, and the influence of the distance between the hole walls and drill on lowering/hoisting speed, as well as to define the minimum clearance between the core and inner surface of core barrel, cutters with different geometrical characteristics were used. The better results were obtained with the bits, which had rake

Table 3. The technological characteristics of ice core drilling by the KEMS-112 electromechanical drill on Vavilov Glacier (29.02.88–25.03.88).

Characteristics		Intervals, m			
		32.2–101.3	101.3–394.3	394.3–457.1	457.1–461.6
Diameter of drill head	mm				
outer		132	116	112	112
inner		107	85 ; 87 ; 89 ; 93	87	93
Length	m				
barrel		1.5	1.5	1.5	1.5
filter		1.45	2.2	2.2	2.2
Chips density in filter	kg/m ³	380–480	360–495	380–475	–
Average length of run	m	0.97	0.93	1.21	0.37
Average rate of penetration	m/h	17.4	21.1	18.2	1.6
Average core production rate	m/day	11.5	20.9	21.0	–

angle 45° or 30° and clearance angle 5°.

The core quality was suitable for various investigations, and its recovery was 100%. It was found that the amount of core pieces recovered from the core barrel depended on the height of the hole liquid. When the penetration was carried out with a hole liquid height of only 20 m, the core was cracked into pieces with length 0.1–0.2 m.

Based on the tests in 1984 and 1986, the drill construction was so improved that in 1988 it could drill bore-hole through the glacier and pierce into subglacial rocks to the depth of 2.3 m. Drilling in the contact zone between the glacier and bedrock and in subglacial sedimentary rocks was carried out by a carbide faced drill head type SA-1 with drilling pressure of 1.2 kN. The driving electric motor consumed about 1.5 kW.

The survey of the third bore-hole and core investigations included inclinometering, cavity metering, thermometering, crystal morphological and petrostructural studies, and isotope oxygen analyses of the ice core, and mineralogical analyses of subglacial rocks.

Inclinometric measurements were carried out 3 times by lowering and hoisting an inclinometer of KIT type in steps of 20 m (Fig. 6). In the upper part of the bore-hole, the inclination angle decreased smoothly from 3.4–3.8° at the depth of 40 m to 2.3–2.4° at the depth of 140 m. Below 140 m the inclination angle was almost constant, it varied in the range of 2.1–2.8°. The magnetic azimuthal angle varied smoothly from 248° at the depth of 100 m to 197° at the bottom. In horizontal projection the bottom was located 18 m from the bore-hole mouth at the general magnetic azimuthal angle of 237°.

The bore-hole diameter was measured four times by lowering and hoisting a type KM-2 lever caliper (Fig. 7). In the interval of 40–170 m the bore-hole walls had small cavities, whose diameter were several mm more than the average diameter. In the interval 170–459 m the bore-hole walls were flat, and the bore-hole diameter was 114–115 mm up to 395 m and 111–112 mm up to 443 m. The diameter near the bottom was 114–115 mm, but in the contact zone between the glacier and bedrocks a big cavity of diameter 125 mm

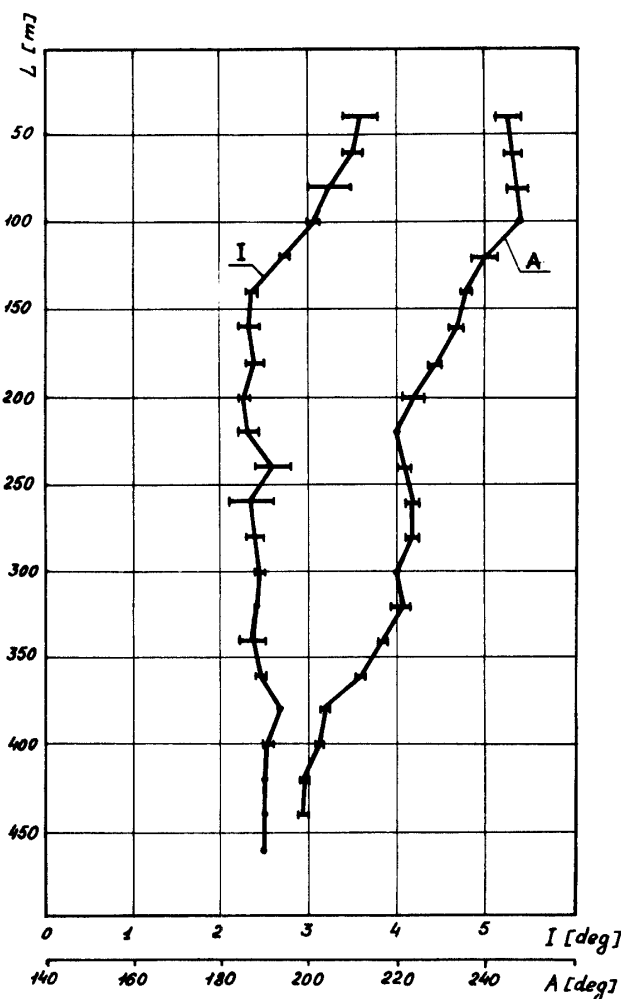

Fig. 6. Inclination of bore-hole 461.6 m versus depth L: I-inclination, A-magnetic azimuth.

was found.

One of the peculiarities of the mechanical drilling technology is the existence of a relationship between the diameters of the bore-hole and core (Fig. 8):

$$D1 = D2 + D3 - D4, \quad (1)$$

where D1 is the bore-hole diameter, D2 and D3 are the outer/inner diameters of the drill head, and D4 is core diameter. The increase of core diameter due to relaxation is unimportant.

In the interval of 40–150 m, calculated bore-hole diameter was less than measured bore-hole diameter by 4–7 mm. This difference was due to increase of bore-hole diameter by lowering/hoisting operations. But below 150 m the calculated diameter was more than the measured diameter, the maximum difference of 6.5–7.0 mm being found at the depths 320–330 and 360–370 m. This means that the bore-hole closed with average speed of 0.13–0.16 mm/day. The compression pressure was 10–13 atm.

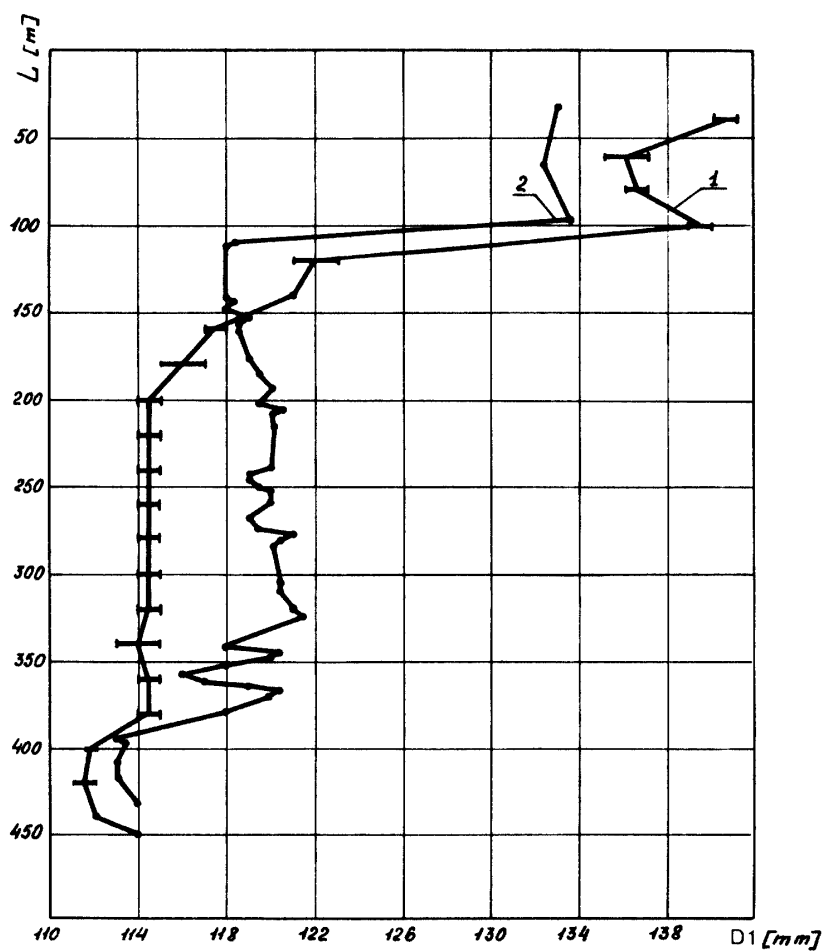

Fig. 7. Bore-hole 461.6 m diameter $D1$ versus depth L : 1-measured diameter, 2-calculated diameter according to formula (1).

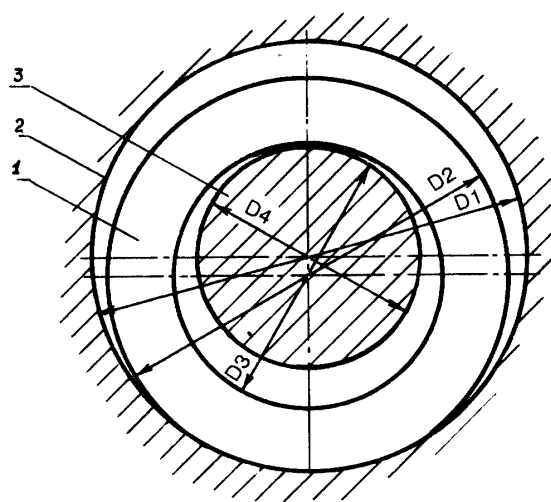

Fig. 8. Scheme of bore-hole bottom during mechanical drilling: 1-drill head, 2-bore-hole walls, 3-core.

Temperature measured by a TSPN-3 type calibrated thermistor monotonously increased from -11.02°C at depth 40 m to -6.02°C at the bottom. The temperature gradient was $0.012^{\circ}\text{C}/\text{m}$ at 40–140 m, $0.015^{\circ}\text{C}/\text{m}$ at 140–260 m, $0.012^{\circ}\text{C}/\text{m}$ at 260–340 m, and $0.009^{\circ}\text{C}/\text{m}$ at 340–460 m.

The boundary between glacier and bedrock was placed at the depth of 459.33 m by the content of ice in the core and texture peculiarities of ice and mineral inclusions. The thickness of debris — containing ice was estimated to be 2.15 m (interval 457.18–459.33 m), where the content of the ice was more than 70%, and mineral material was in suspended condition. The length of the bedrock core was 2.28 m (interval 459.33–461.61 m). It was characterized by less than 50% ice content and by typical structures and textures of permafrost. Mineral materials included red-brown siltstones, sandstones and mudstones (BOLSHIYANOV *et al.*, 1990).

The petrostructural study showed that the zone of shift deformation connected with glacier movement was located at the boundary between glacier and bedrock in the intervals 457.37–457.49 and 457.85–457.90 m. The age of ice at the bottom of the bore-hole was estimated using isotope oxygen analyses as 8–10 thousand years (KLEMENTIEV *et al.*, 1991).

4. Drilling Operations at Vostok Station

In April 1989, ice core drilling of the deep bore-hole 4G at Vostok Station by a TBZS-152M type thermal drill (for a detailed description of thermodrilling see KUDRYASHOV *et al.*, 1991a) was finished at depth 2428.5 m, because of the possibility of occurrence of an accident in the hole. This situation was caused by deficient compensation of the confining pressure. The density of the hole liquid was only $840\text{--}850\text{ kg}/\text{m}^3$, and because of the bad state of the upper part of the hole its level was at the depths 180–200 m. So the compression pressure at the bottom of the hole was more than 32 atm. In consequence of the hole closure, at depths below 2000 m during drill lowering constant wedges occurred. This made it necessary to enlarge narrowing parts of the hole, and the time of drill lowering from the depth of 2000 m to the bottom was two hours and more. Besides, the danger of drill loss during hoisting was great.

During three months, preparatory work for electrodrilling was carried out in a drilling complex built in 1983–1984 for thermodrilling. Near the mouth of the bore-hole the assembling/disassembling device was mounted. On the special stand 92 experiments were carried out in order to calibrate sensing elements and to train drilling staff. Then about 2 t of densifier was added to the hole. The measured densities of the hole liquid were $923\text{ kg}/\text{m}^3$ at depth 190 m (temperature -56°C) and $842\text{ kg}/\text{m}^3$ at depth 2426 m (temperature -28°C). Density was measured by densitometers with accuracy $0.5\text{ kg}/\text{m}^3$ under atmosphere pressure. Unfortunately the mixing by lowering and hoisting of the drill was not effective, and the main part of the densifier was located in the upper part of the hole liquid.

Drilling of bore-hole 4G was resumed in June of 1989 by a KEMS-112 electromechanical drill. The cavity diameter at the bottom of the hole was more than 200 mm; the maximum antitorque system diameter was only 190 mm. For recording of antitorque system turning a special element was mounted in the drill.

Serious difficulties were met in first runs, during the drill lowering with speeds from 1 to 50 m/h. When the bits had contact with the bottom, wedging of the core chamber and driving electric motor occurred. At the same time it was established that the drill with special conic drill head intended for bottom cleaning was descended without problems. Drilling from 2428.5 to 2435.2 with normal collar and conic drill heads required 77 runs. The length of the run reached 1.0 m. Core recovery in this interval was 72%.

At the depths of 2431.7 and 2437.5 m after penetration of, respectively, 0.15 and 0.75 m, the core chamber was wedged, and the drill was stuck. Using the hammer block and cable tension the core chamber and drill were freed, in five days the first and two hours the second.

Then the drilling process was stabilized (Table 4). The drilling technology included core drilling with 132 mm drill head and periodic enlarging up to the depth of 2524.8 m with 135 mm drill head. Energy consumption of the driving electric motor was about 3 kW taking cable loss into account. The electric pump motor consumed about 2.5 kW. The average time of one run was 3.7 h, including lowering 0.95 h, letting down to the bottom 0.1 h, penetration 0.21 h, core breaking 0.1 h, hoisting 1.67 h, maintenance on the surface 0.67 h. The ice core from the interval 2451.3–2546.4 m was of good quality, its recovery was 97–100%.

Table 4. The technological characteristics of ice core drilling by the KEMS-112 electromechanical drill at Vostok Station (16.06.89–06.09.89).

Characteristics		Intervals, m		
		2428.5–2435.2	2435.2–2451.3	2451.3–2546.4
Diameter of drill head	mm			
	outer	132 ; 135	132 ; 135	132 ; 135
	inner	107	107	107
Length	m			
	barrel	0.5–1.5	1.5	3.0
	filter	1.5	1.5	4.5
Chips density in filter	kg/m ³	–	350–450	370–460
Average length of run	m	–	0.89	2.57
Average rate of penetration	m/h	–	7.2	12.5
Average core production rate	m/day	–	–	6.8

At the depth of 2546.4 m the drilling was interrupted for 16 days for the reeling of cable with length 4000 m instead of 2600 m. In the first run after the resumption drilling was made 1.8 m without any trouble. After switching the electric motor off, hoisting of the drill was begun, but the drill was stuck 1 m above the bottom. The drill was not moved even by the tension in the 90 kN cable. The drill was left for one year with the tension in the cable, but in November 1990 the cable was broken near the mouth of the bore-hole.

In the intervals between drilling operations, a bore-hole survey was carried out. The

bore-hole direction was measured by a KIT type inclinometer with steps of 20 m. In the interval 2428.5–2546.4 m drilled by the KEMS-112 electromechanical drill, the inclination angle was varied in the range 1.0–1.9° with smooth changes of magnetic azimuth in the range 212–217°. In horizontal projection the bottom was located about 200 m from the bore-hole mouth at the general magnetic azimuthal angle of 106°.

The bore-hole diameter was measured by a KM-2 type caliper with accuracy 1 mm (Fig. 9). In the interval 2428–2450 m the bore-hole had big cavities with diameter to 150 mm. In the part of the bore-hole below 2450 m the bore-hole walls were flat. There were small cavities with maximum diameter 139 mm. The average bore-hole diameter was 134–135 mm in the interval 2450–2525 m and 133–134 mm below 2525 m.

The calculated diameter according to formula (1) in the interval 2524.8–2546.4 m drilled without enlarging was about 137.0–137.5 mm. It is possible to explain such a

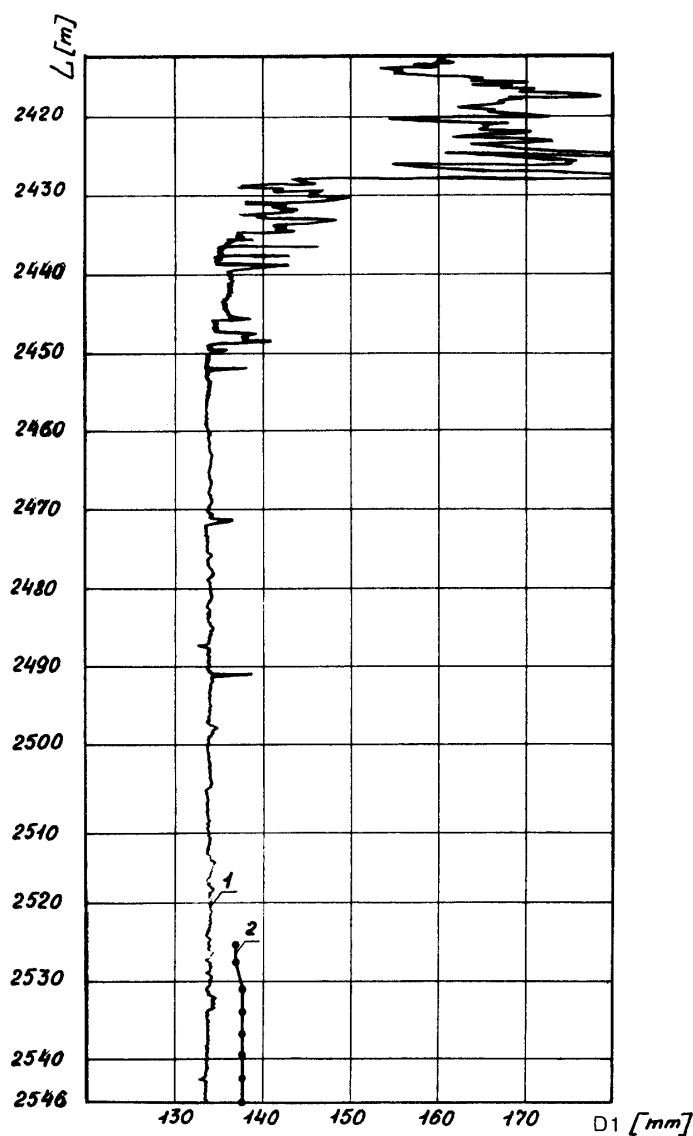

Fig. 9. Diameter D_1 of bore-hole 4G lower part versus depth L : 1-measured diameter, 2-calculated diameter according to formula (1).

discrepancy by rapid closing of the bore-hole at deep depths. The compression pressure at the depth of 2500 m was about 28 atm. The comparison of the cavity meter data, obtained three hours after the drilling, and calculated diameter allows us to estimate the average speed of the hole closure as 1.0–1.2 mm/h for this period. In our opinion, in the condition of non-full confining pressure compensated by hydrostatic pressure, the most rapid hole closure took place immediately after penetration.

5. Conclusions

For the first time in the Russian Arctic, successful complete core drilling in a glacier and penetration in to subglacial frozen rocks were done using the KEMS-112 electro-mechanical drill. This event is considered to be important not only from the technical point of view, but it opens a new stage in studying the dynamics of glaciers and their connection with bedrock.

The deepest bore-hole in Antarctica was deepened by the KEMS-112 electro-mechanical drill, and a Russian-French-USA collaborative study of the ice core made it possible to reconstruct the climate of the Earth during the last 200 thousand years (KOTLYAKOV *et al.*, 1991).

Acknowledgments

We would like to thank V.V. UFAEV, V.K. CHISTYAKOV, G.V. DENISOV and other specialists of the St. Petersburg Mining Institute for their help in construction and testing.

We would also like to thank geophysicists of St. Petersburg Mining Institute, E.M. ZOLOTOV, K.V. BLINOV and A.N. MARKOV, who made field measurements and provided inclinometer, cavity meter and temperature data.

Field testing was done through the Earth Ocean Program under support of the Arctic and Antarctic Research Institute.

References

- BOBIN, N.E., VASILIEV, N.I., KUDRYASHOV, B.B., STEPANOV, G.K. and TALALAY, P.G. (1988): Mekhanicheskoe burenie skvazhin vo ldu (Mechanical bore-hole drilling in ice). Leningrad, Leningradsky Gorny Institut (Leningrad Mining Institute), 1–90.
- BOLSHIYANOV, D. Yu., KLEMENTIEV, O.L., KOROTKOV, I.M. and NIKOLAEV, V.I. (1990): Issledovaniya kerna morenosoderzhashchego lda lednika Vavilova na Severnoy Zemle (Studies of debris-containing ice core from the Vavilov Dome, Severnaya Zemlya). Mater. Glatsiol. Issled. (Data Glaciol. Studies), **70**, 105–110.
- GUNDESTRUP, N.S., JOHNSEN, S.J. and REEH, N. (1984): ISTUK: a deep ice core drill system. CRREL Spec. Rep. **84-34**, 7–20.
- KLEMENTIEV, O.L., NIKOLAEV, V.I., POTAPENKO, V.Yu. and SAVATYUGIN, L.M. (1991): Vnutrennee stroenie i termogidrodinamicheskoe sostoyanie lednikov Severnoy Zemli (Internal structure and thermohydrodynamic state of glaciers on Severnaya Zemlya). Mater. Glatsiol. Issled. (Data Glaciol. Studies), **73**, 103–109.
- KOTLYAKOV, V.M., NIKOLAEV, V.I., KOROTKEVICH, E.S., PETROV, V.N., BARKOV, N.I., LIPENKOV, V.Ya., LORIUS, C., JOUZEL, J., BARNOLA, J.M. PETIT, J.-R., RAISBECK, G. and RAYNALD, D. (1991): Posledniy klimaticheskii tsikl Zemli: dannye kompleksnyh Issled. antarcticheskikh ledyanih kernov (The last climatic cycle of the Earth: the data of complex studies of Antarctic ice cores). Mater. Glatsiol. Issled. (Data Glaciol. Studies), **73**, 11–18.

- KUDRYASHOV, B.B., CHISTYAKOV, V.K. and LITVINENKO, V.S. (1991a): Burenie skvazhin v usloviyah izmeneniya agregatnogo sostoyaniya gornih porod (Bore-hole drilling in the condition of rock aggregate changes). Leningrad, Nedra, 1-295.
- KUDRYASHOV, B.B., CHISTYAKOV, V.K., VASILIEV, N.I. and TALALAY, P.G. (1991b): Burenie skvazhin s otborom kerna electromechanicheskim snaryadom na gruzonesushchem kabele v lednikovyh i podlednikovyh porodah (The drilling of bore-holes with core selection by an electromechanical drill on load-carrying cable in glaciers and subglacial rocks). Mater. Glatsiol. Issled. (Data Glaciol. Studies), **71**, 165-170.
- PASHKEVICH, V.M. and CHISTYAKOV, V.K. (1989): Obespechenie ustoychivosti stvola skvazhini pri glubokom burenii v lednikovih pokrovah (Ensuring of bore-hole shaft stability when deep drilling in the ice covers). Antarktika (The Antarctic), **28**, 39-50.
- UEDA, H.T. and GARFIELD, D.E. (1969): Core drilling through the Antarctic ice sheet. CRREL Tech. Rep., **231**, 17 p.
- VASILIEV, N.I., TALALAY, P.G. and UFAEV, V.V. (1988): Rezultati stendovih eksperimentalnih Issled. bureniya lda mechanicheskim burovim snaryadom KEMS-112 (The results of stand tests investigations of drilling in ice by mechanical drill KEMS-112). Zap. Lening. Gorn. Inst. (Trans. Leningr. Mining Inst.), **116**, 82-86.

(Received April 30, 1993; Revised manuscript received January 31, 1994)