

Mem. Natl Inst. Polar Res., Spec. Issue, **56**, 38-48, 2002

FELICS, a new ice core drilling system for high-altitude glaciers

P. Ginot^{1,2}, F. Stampfli³, D. Stampfli³, M. Schwikowski^{2,*}
and H.W. Gäggeler^{1,2}

¹*Department of Chemistry and Biochemistry, University of Bern,
Freiestrasse 3, CH-3012 Bern, Switzerland*

²*Paul Scherrer Institute, CH-5232 Villigen PSI, Switzerland*

³*FS Inventor AG, Muristrasse 18, CH-3132 Riggisberg, Switzerland*

Abstract: A new solar powered portable system for ice core drilling was developed especially for work on very high altitude glaciers requiring an extremely light and easy to use system. FELICS (Fast Electromechanical Lightweight Ice Coring System), with a net weight of 228 kg for the complete drilling system including power supply, represents a new design. The main features are the absence of an outer barrel and a tilting table, and the use of a one-piece cutting ring, which simplify utilisation of the device and make it very efficient. In addition, FELICS is designed to be installed inside a protective tent, effectively allowing a 24 hour working day. The new drilling system has been successfully employed in the European Alps and in the Andes (on Cerro Tapado, Chile at 5536 m a.s.l., on Illimani, Bolivia at 6300 m a.s.l. and on Chimborazo, Ecuador at 6250 m a.s.l.) with a drilling performance of 136 m in only 6 working days. In addition, a small version of FELICS for maximum depths of 18 m was developed for exploratory studies.

1. Introduction

In order to reconstruct climate and atmospheric chemistry information from glacier ice cores, it is imperative to find glaciers sufficiently cold so that the records are not disturbed by melt water percolation. Moreover, it is necessary to find sites where the topography allows a significant accumulation of ice without disturbing ice flow, which restrict the main possibilities to glacier saddles and to glaciers located on mountain summits or in craters. These conditions exist primarily at very high altitudes, *e.g.* above 4000 m in the European Alps and above 5500 m in the Andes and in the Himalaya. In the Andes, the highest drilling has been performed at the top of Sajama at 6542 m (Thompson *et al.*, 1998), whereas another drilling expedition reached an altitude of 7000 m on the slopes of Xixiabangma in Tibet (Thompson *et al.*, 2000). Working conditions at such high altitudes are extremely demanding for humans and for the material. There are physiological difficulties and it is even dangerous to “live” several weeks above 6000 m. To limit the duration of drilling and thereby the time spent at these altitudes, it is best to benefit from

*Corresponding author: Margit Schwikowski, Paul Scherrer Institute, CH-5232 Villigen PSI, Switzerland. Tel: +41 56 310 4110, Fax: +41 56 310 4435 (margit.schwikowski@psi.ch)

an easy to use drill device, not requiring long and laborious assemblage and allowing fast drilling. Moreover, the weight is the principal limiting factor since all material must be transported to the drilling site by porters. Transport by helicopter is restricted to altitudes lower than about 5000 m. The aim of developing the innovative drilling system FELICS (Fast Electromechanical Lightweight Ice Coring System) presented here was primarily to satisfy the requirements of facility of use and low-weight. FELICS allows a drilling depth of 200 m and extracts 78 mm diameter ice cores. In addition, a small ultra-light version of FELICS was designed for exploratory drillings. Using it, ice cores of 58 mm diameter can be recovered down to a maximum depth of 18 m in just a few hours.

2. General design of FELICS

The new ice core drill device FELICS was designed and manufactured in 1998 by the company FS Inventor AG in collaboration with the Paul Scherrer Institute and the University of Bern in Switzerland. The complete system can be installed inside a commercial protective tent (Figs. 1 and 2) and does not require trench excavation since it is a non-tilting drill. It is composed of 3 principal parts, the drill, winch and power supply, and is very light with a net weight of 228 kg including power supply (Tables 1 and 2). The assembling of FELICS requires only a minimum set of tools, winch and tower installation in the tent may be performed in only 30 min by three people. This is very short compared to the time required for assemblage of other systems (Koci and Zagorodnov, 1994; Zagorodnov *et al.*, 2000; Blake *et al.*, 1998). The heaviest component is the cable drum with 200 m cable, which weighs 28 kg. Even under quite difficult climbing conditions the complete system can be transported in about eight porter loads. All parts in contact with ice are made from anodised aluminium, stainless steel, polyethylene and polyoxymethylene (Delrin © DUPONT).



Fig. 1. Installation of FELICS inside the protective tent on top of Cerro Tapado (Chile, 5536 m a.s.l.) in February 1999. The 6 flexible solar panels used as a power supply are visible in the front.

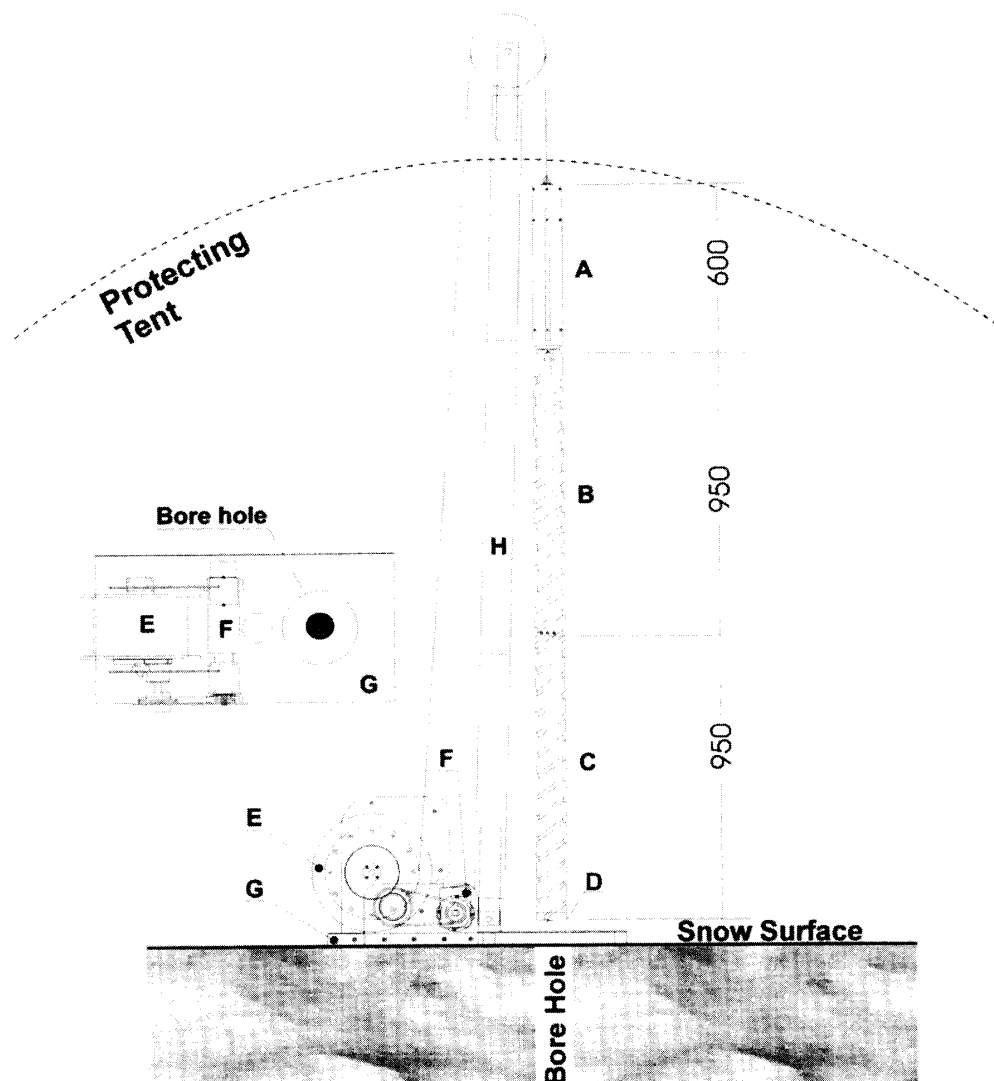

Fig. 2. The main components of the drill: A—the drive unit with motor and anti-torque system, B—the short chips barrel with the spiral allowing transport of the chips to the two openings on the top of the barrel, C—the core barrel, D—one piece cutting ring, E—winch with cable, F—winch motor, G—winch base plate and H—the 3 pieces of the tower installed inside the protective tent, (size in mm). Insert: view from the top onto the winch base plate.

3. The drill

The drill is composed of four parts: (1) the cutting ring, (2) the ice core barrel, (3) the chips barrel and (4) the drive unit with anti-torque system.

Instead of using individual cutting teeth, we constructed and machined a complete cutting ring (Schwander and Rufli, 1989) with two cutters (Fig. 3) out of a solid block of specially hardened aluminium, and equipped it with either two or four core catchers. Even for non-technicians it is very easy to replace the cutting ring without adjustments just by opening six screws. One of the two teeth, with a penetration angle of 55° , cuts 2 mm

Table 1. Specifications of the FELICS drilling system. The system can be dismantled in 12 principal parts, not including the power supply and the protective tent. The weight of the complete system is 228 kg.

	Part	Dimensions (mm)	Weight (kg)
DRILL 41 kg	Drive unit and anti-torque	Ø 100 x 600	25
	Core and chips barrel	2 pieces: Ø 100 x 950	2 x 8
FIX INSTALLATIONS 122 kg	Drill tower	3 pieces: Ø 120 x 900	3 x 9
	Winch base plate	1000 x 500 x 200	22
	Winch motor	400 x 150 x 150	12
	Cable drum and 200 m cable	Ø 400 x 220	28
	Control box	300 x 200 x 180	3
	Protection tent	1000 x 400 x 350	20
	Small parts		10
POWER SUPPLY 65 kg	Solar panels	6 pieces : 1200 x 450 x 10	6 x 2
	Battery pack	2 pieces : 400 x 170 x 150	2 x 20
	Generator	550 x 400 x 250	13

Table 2. Specifications of FELICS and of its small version.

	FELICS	FELICS-small
Core/borehole diameter (mm)	76/103	58/73
Max. core/drill length (mm)	900	900
Drill/winch weight (kg)	41/122	18
Drill/winch power (W) (rated power)	250/420	70
Power system weight (including fuel for 100 m) (kg)	65+20	7
Production rate	50 m/day	10 m/h
Installation time (min)	30	10

deeper but only a narrow ring around the core. The second tooth cuts the outer part of the annulus. The geometrical pitch is 3.5 mm/revolution, but the drill speed is controlled with the winch speed. The cutting edges of the teeth can be restored or modified in the field with needle files but one cutting ring can be used for a 150 m deep core drilling if there are no high concentrations of particles. The core catchers follow the conventional "bird beak" design; three different sizes are used for firm, soft ice and hard ice. It is also possible to use only two core catchers for extraction of hard ice cores.

The core barrel is 950 mm long, has an outer diameter of 100 mm, an inner diameter of 78 mm and the maximum length of ice cores is 90 cm (Table 2). The principal innovation of the drill is the absence of an outer barrel (see Figs. 2 and 4) around the core or chip barrel, which considerably simplifies the removal of the core after drilling. Manipulation of the couplings among core barrel, chips barrel and the drive unit is easier and the working space is reduced, so that it is possible to drill protected inside a commercial geodesic dome tent (2 Meters Dome, The North Face, Inc. USA, Fig. 1). The

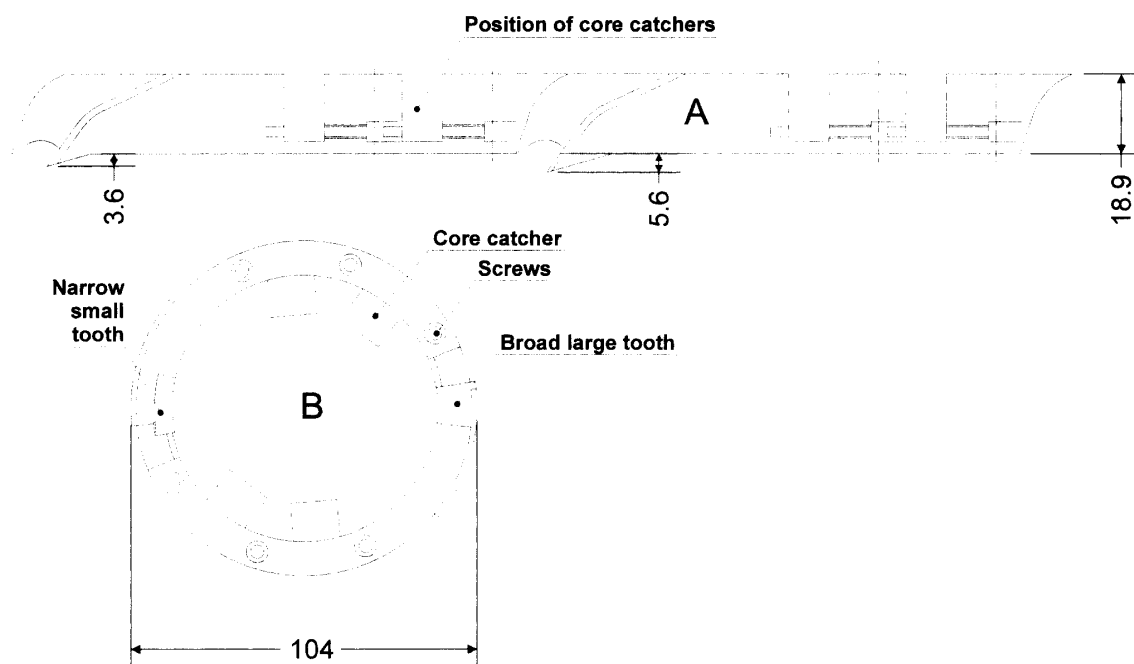

Fig. 3. Unrolled drawing of the one-piece cutting ring (A) and illustration showing the position of the 4 core catchers and the cutters (B) (sizes in mm).

function of an outer barrel is twofold: it guides the chips upwards and prevents the core barrel from sticking in the bore hole. Without an outer barrel, but with a velocity of 220 revolutions per minute, the centrifugal force is sufficient to keep the chips in contact with the ice wall of the bore hole and transport them to the top of the chips barrel where they fall through two openings. The two parallel transporting spirals on the outside of the core and chips barrel are in complete contrast to the conventional design; they are narrow and machined out of a thick-walled aluminium tube. Since their width is continuously increasing to the top, there is almost no danger of over-filling the spiral and subsequently blocking the drill in the hole. Inherent in every drilling process is the danger of blocking the drill if drilling is continued when the chips barrel is already filled. In order to avoid this problem, we use two chips barrels of different lengths. The longer one (1200 mm) allows a 90 cm core to be drilled in high-density ice without overloading the chips barrel. The short one (950 mm) is used for firm with lower density.

The drive unit consists of the drive motor, the cable connection and the new anti-torque system. A 60 V-4.2 A DC-Motor (Dunker GR 80×80) with a reduction gear (PLG 70, I=28 : 1) is used as the motor. The torque of the drive motor is transmitted to the ice with three hollow-cut, spring-loaded knives (Figs. 2, 4, 5B). To prevent blocking with snow or ice they fit snugly in slots of the drive-unit casing. The drive unit cable connection is equipped with a slip ring to prevent cable torsion, but we have never observed slipping of the anti-torque unit under normal use.

A very simple system was developed to couple the drive unit, the ice core barrel, and the chips barrel (Fig. 5A). Two spring-loaded pistons glide radially into two holes of the thick-walled barrel. To disengage the coupling, a U-shaped tool is pushed into tangential slots of the barrel. The separation of the barrels to extract ice cores and chips is performed

FELICS ice core drilling system

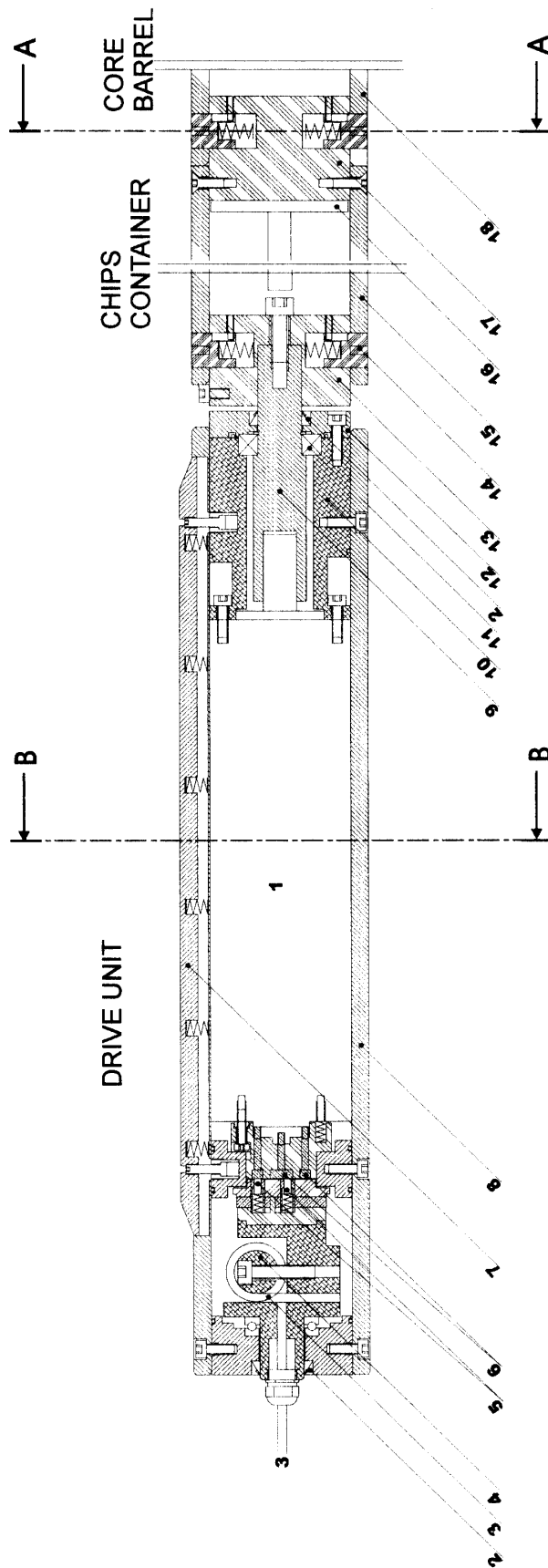

Fig. 4. Cross section design of the complete FELICS drill system. (1) DC-Motor (60 V, 4.2 A, Type Dunker GR 80 × 80) with reduction gear (Type PLG 70, $r=28:1$), (2) circular seal (Lubroseal LM17C), (3) steel cable, (4) cable clamp, (5) electrical contactors, (6) slip-ring, (7) anti-torque system, (8) jacket, (9) shaft, (10) motor support, (11) ball bearing, (12) bearing cover, (13) motor clutch, (14) clutch bolt, (15) chips container, (16) chips extractor, (17) drill clutch, (18) core barrel.

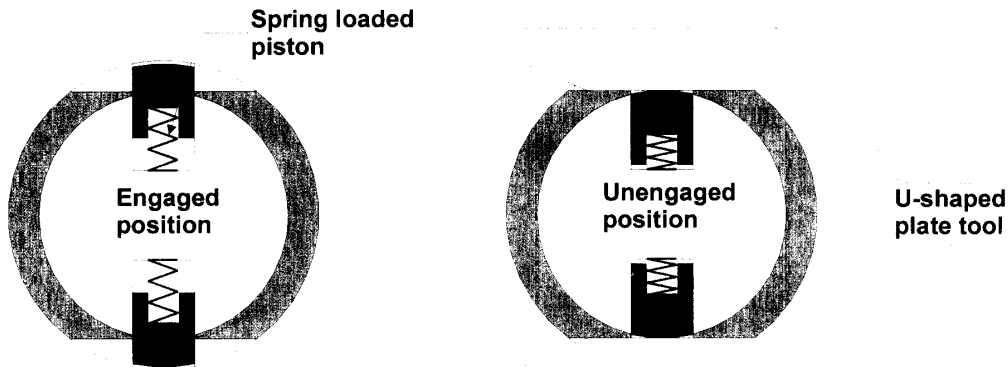

Fig. 5A.

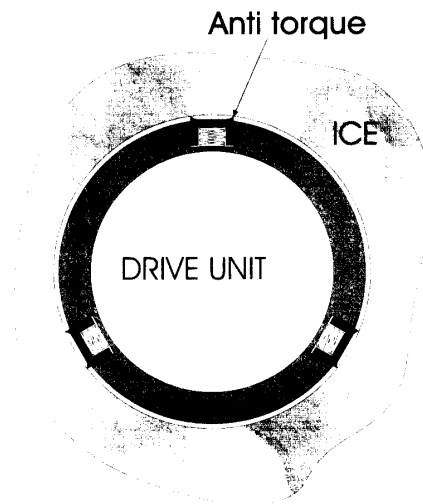

Fig. 5B.

Fig. 5. Coupling system between motor, chips barrel and core barrel (A, section AA in Fig. 4) and the new anti-torque system (B, section BB in Fig. 4).

in a vertical position without using a tilting table. The cores and chips are extracted from the barrels by means of a simple core pusher and chips extractor. The absence of a non-rotating outer barrel and the ingenious coupling system permit precious time to be gained during drilling.

4. Cable, winch, tower and control box

A 6.5 mm diameter coaxial (8×7) steel cable (Gebrüder Wanner, Ulm, Germany) which only weighs 15.2 kg per 100 m and has a rupture load of 22.2 kN was used on Illimani. A copper conduit of 0.96 mm² in the centre of the cable is utilized for current conduction. The specific conductivity is 1.8 Ω per 100 m for the copper lead and 1.5 Ω per 100 m for the steel mantle. With an output power of 120 V and 2 A from the battery pack to the drive unit, the loss in the cable is only 8% at a drilling depth of 150 m. The cable

is quite stiff, so it can withstand rough handling. However, a new 4.7 mm diameter steel cable (Câbles Vector SA, France) with 4 copper conduits (0.22 mm^2) was used for the new version of FELICS on Chimborazo, which presents lower but sufficient resistance (7 kN) and reduced weight (9.3 kg per 100 m). For transport, the cable and current connector are separated from the drive unit by taking out six screws.

Easy handling, handy transport units and simple installation were the aims in designing the winch and tower. Both components are installed on a 5 mm thick aluminium base plate equipped with a stabilising frame. The cable drum is fixed by a sliding axes which also connects the cable electrically. The 0.42 kW winch motor (120 V, 4 A, 3000 rotations/min) coupled to a 25 : 1 reduction system is normally fixed onto the base plate but can be quickly separated for transport. The 3-piece-tower can be clicked together in seconds without any tools and is mounted onto the base plate by an axis. It is stabilized with four firm-anchors outside the protective tent.

The complete system is operated from a compact control box including an on-off current switch, a battery pack voltage meter, a solar panel/generator input current meter and the winch and drill switches. An up-down switch and a speed regulator, which allows a maximum speed of 0.5 m/s, control the winch. A low speed position allows the winch to be controlled during drilling. The drill is controlled with a rotation speed regulator and a rotation direction button. The winch and drill motor power are controlled by two servo-amplifiers (20 A) and are equipped with current-meters to check sticking of the drill, ice hardness or chips barrel filling. The depth of the bore hole is monitored by a counter installed on the winch, but is also directly measured by a 150 m long ballasted band meter attached to the tower.

5. The power supply

Two independent power sources are used, allowing drilling during day and night. A group of six flexible solar panels (see Fig. 1) with a peak power of 190 W (USF-32, Unisolar) and a small gasoline generator with nominal output of 1000 W (EU 10, Honda) are connected to a rechargeable battery pack (capacity 840 Wh, 120 V/7 Ah) in continuous loading. The solar panels supply enough power to work with either drill or winch motor load when sufficient sunlight is available. Drilling with the battery pack can be continued for several hours without sunlight. In addition, the battery pack delivers the necessary peak power for core breaking and winch acceleration.

The commercial gasoline generator is extremely compact with a weight of only 13 kg and has been completely reliable. By changing the gasoline injection nozzle (15 min work in the field), the generator functions even at altitudes above 6000 m and it only consumes about 0.5 litre gasoline per hour. This low consumption reduces the total amount of gasoline needed to about 30 kg. Even starting in the morning at temperatures of about -20°C never posed any problems. Due to the low air pressure at high altitude the power output is reduced to about one third of nominal capacity. Nevertheless, during drilling on the Illimani at 6300 m, the coupled solar panels and generator provided enough energy (500 W) for charging two battery packs used for simultaneous drilling with two FELICS devices.

6. Drill test and performance

During winter 1998, we performed a test drill reaching 20 m depth on the Jungfrau-joch temperate glacier (Swiss Alps, 3500 m a.s.l.). In February 1999, a first scientific drilling expedition using FELICS was conducted on the Cerro Tapado glacier at 5536 m a.s.l. in the Chilean Andes (Fig. 1, Ginot *et al.*, in preparation) where the bedrock was reached at a depth of 36 m in only two drilling days. In the same year, a drilling was performed in collaboration between the Paul Scherrer Institute and the IRD (French Institute of Research for Development) near the summit of Illimani in Bolivia at an altitude of 6300 m a.s.l. The simultaneous use of two FELICS devices allowed extraction of two 136 m long ice cores in only 6 working days on site. In November 2000, four ice cores were recovered from Chimborazo summit in Ecuador at 6250 m a.s.l.; one reached the bedrock at 55 m depth.

In reasonable working conditions it is possible to drill 50 m in 10 working hours and 150 m in about 50 working hours. In order to guarantee the smooth transport of drilling chips, core and chips barrel should have temperatures below 0°C. Thus, especially in tropical areas and in summer, drilling of the first meters during the night is recommended in order to avoid heating drill parts during daytime.

7. A small version of FELICS

For exploratory studies, we developed a small version of FELICS (58 mm core diameter with a maximum length of 90 cm, Table 2), which is especially simple to use. This drilling system is composed of the same assembly of core barrel, chips barrel and drive unit (Fig. 6). The system is attached to an electric lifting cable of 20 m length which is connected to a small control box and a battery pack. Because of the reduced core diameter, it was necessary to design a different type of core dog in order to extract cores without damaging them. Core dogs with horizontal mobility are used to cut the core by extracting knives through backward rotation of the drill (Suzuki, 1984). These core dogs are especially suitable for the first meters of drilling of snow and firn with densities below 0.6 g/cm³ and in the absence of ice layers. For denser firn and ice, a small version of the FELICS core dogs is available. Power is provided by 4 small solar panels (USF-11, Unisolar) via a battery pack (18 V, 4 Ah). Since no winch is used, the total weight of the drill system is reduced to 20 kg. Drilling of 15 m firn cores only requires about 2 to 4 working hours. Because of the low weight of the drill, it was difficult to pass through ice layers of more than 5 cm thickness. In order to apply stronger pressure to the drill, we therefore use an assembly of connectable stakes attached to the top of the engine.

8. Conclusions

The innovative fast electromechanical lightweight ice coring system FELICS met the requirements for ice core drilling on high altitude glaciers, *i.e.* it is lightweight as well as effective and easy to use. The main improvements compared to other devices are the absence of an outer barrel and a tilting table, and the use of a one-piece cutting ring, which together simplify use of the device and make it very efficient. Successful drillings reaching



Fig. 6. Small version of FELICS used on Cerro Tapado, Chile, in February 1998. Power is supplied by 4 small solar panels coupled to an 18 V battery pack.

bedrock were conducted with the new drill at the top of Cerro Tapado (Chile, 5536 m), of Chimborazo (Ecuador, 6250 m) and of Illimani (Bolivia, 6400 m). On Illimani, two 136 m long ice cores were extracted in only 6 working days. During the drilling on Illimani, just 3 m of the 136 m core was shredded, indicating that FELICS allows the extraction of high quality ice cores.

Acknowledgments

The Swiss National Science Foundation, Project # 21-50854.97, supported the acquisition of FELICS. The drilling campaigns in the Andes were conducted in collaboration with IRD and we would especially like to thank Bernard Pouyau, Robert Gallaire (IRD, Bolivia) and Bernard Francou (IRD, Ecuador) for their engagement in the field. Appreciation is expressed to the Chilean Army (Regimiento de Infantería N° 21 "Arica") for the support of the fieldwork in Chile. The comments of the reviewer Victor Zagorodnov improved the clarity of this manuscript, and we are grateful for his suggestions.

FELICS is commercialised by FS Inventor AG (www.icedrill.ch).

References

- Blake, E.W., Wake, C.P. and Gerasimoff, M.D. (1998): The Eclipse drill: a field-portable intermediate-depth ice-coring drill. *J. Glaciol.* **44**, 175–178.
- Koci, B. and Zagorodnov, V. (1994): The Guliya ice cap, China: retrieval and return of a 308 m ice core from 6200 m altitudes. *Mem. Natl Inst. Polar Res., Spec. Issue*, **49**, 371–376.
- Schwander, J. and Ruffli, H. (1989): Electromechanical drilling in dry holes to medium depths. *Ice Core Drilling. Proceedings of the Third International Workshop on Ice Drilling Technology, Grenoble-France, 10–14 October 1988*, ed. by C. Rado and D. Beaudoin. 32–37.
- Suzuki, Y. (1984): Light weight electro-mechanical drills. *CRREL Spec. Rep.*, **84-34**, 41–44.
- Thompson, L.G., Davis, M.E., Mosley-Thompson, E., Sowers, T.A., Henderson, K.A., Zagoradnov, V.S., Lin, P.N., Mikhaleiko, V.M., Campen, R.K., Bolzan, J.F., ColeDai, J. and Francou, B. (1998): A 25000-year tropical climate history from Bolivian ice cores. *Science*, **282**, 1858–1864.
- Thompson, L.G., Yao, T., Mosley-Thompson, E., Davis, M.E., Henderson, K.A. and Lin, P.N. (2000): A high-resolution millennial record of the South Asian Monsoon from Himalayan ice cores. *Science*, **289**, 1916–1919.
- Zagorodnov, V., Thompson, L.G. and Mosley-Thompson, E. (2000): Portable system for intermediate-depth ice-core drilling. *J. Glaciol.*, **46**, 167–172.

(Received February 1, 2001; Revised manuscript accepted June 15, 2001)